



TESTED PRODUCTS
EFFICIENT SERVICE
TRUSTED BRAND

An ISO 9001: 2015 Company

Product Catalog



Grounding Systems

Cable Lugs & Connectors



Also Includes

[Axi-Weld - Exothermic Welding](#)

[Cable Ties](#)

[Insulator Hardware Fittings](#)

Cable Lugs & Connectors

Axis manufactures high quality lugs and connectors used in L.V, M.V and H.V electrical systems. The products are designed, manufactured, tested and comply with International standards like BS, DIN, UL and IEC. Axis Connectors, comprising of Copper, Aluminium and Bi-metallic, ranging from size 0.5 sq.mm to 1000 sq.mm and can be installed with readily available crimping tools.

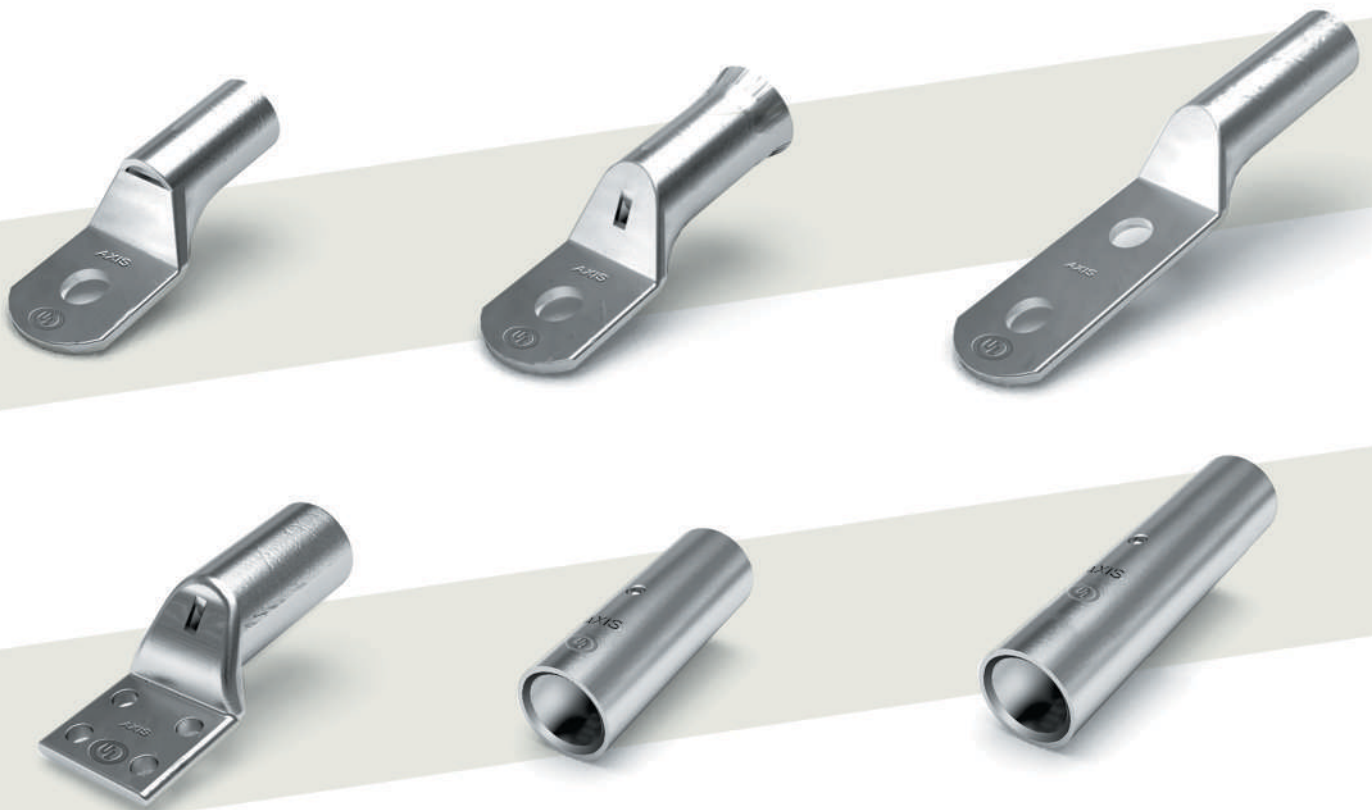

Parallel Groove Clamps AL to AL / Dual Rated

Material : Aluminum Alloy, Bolts - Galvanised

Finish : Natural or Electro-Tinned For Dual Rating

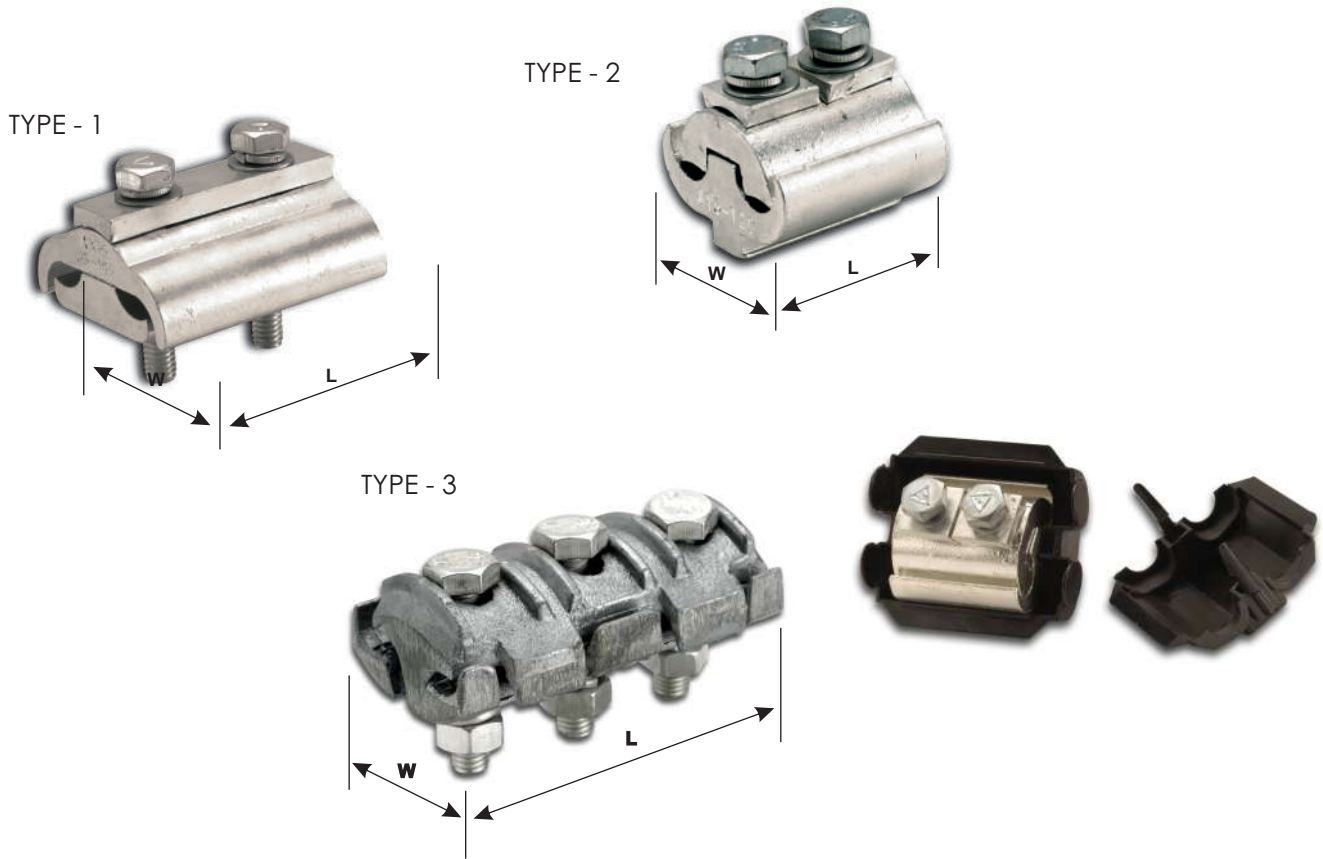

Conductor Size		Conductor Dia Inches	DIMENSION IN INCHES		No. Of Bolts	Type	E-Code
Min	Max		W	L			
6 AWG	2/0 AWG	0.177 - 0.433	1.417	1.811	2	1	APG00001B2
2 AWG	350 KC MIL	0.323 - 0.709	2.165	2.559	2	1	APG00003B2
2 AWG	350 KC MIL	0.323 - 0.709	2.165	3.819	3	1	APG00004B3
6 AWG	1 AWG	0.177 - 0.374	1.260	1.024	1	2	APG00005B1
6 AWG	4/0 AWG	0.177 - 0.512	1.732	1.654	2	2	APG00006R2B2
6 AWG	4/0 AWG	0.177 - 0.512	1.772	1.969	2	1	APG00002B2
6 AWG	4/0 AWG	0.177 - 0.512	1.772	2.953	3	1	APG00002B3
2 AWG	500 KC MIL	0.323 - 0.827	2.559	2.559	2	1	APG00013B2
2 AWG	500 KC MIL	0.323 - 0.827	2.559	3.819	3	1	APG00008B3
4 AWG	3/0 AWG	0.256 - 0.520	1.575	2.953	2	3	APG00010B2
2/0 AWG	300 KC MIL	0.433 - 0.642	2.087	3.858	3	3	APG00009B3

Lightning Protection & Grounding Systems

The first step in designing a Lightning Protection & Grounding system is Risk Assessment for a structure. Axis provides an online Risk Assessment Tool based on the guidelines from IEC 62305 Part 2. The Axis Risk Assessment Tool uses a range of parameters that allow users to determine risk to their structure and thus the Class of Lightning Protection System (LPS) that is required.

Axis Grounding systems follow International Standards like UL 467, BS 6651 & BS 7430 and are approved by leading Electrical Distributors and Consultants worldwide. These Products are easy to install & highly reliable and are manufactured and tested under stringent ISO quality control measures. AXIS Grounding systems are used around the world in core sectors of the economy such as Power, Industrial applications, Oil & many more.



Clamps, Bonds & Accessories

RCC

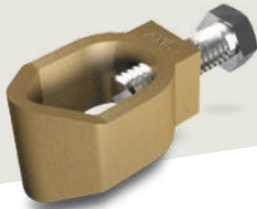

SCG



URC

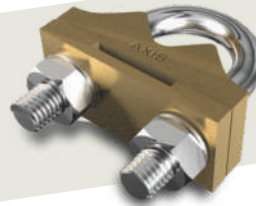

GUV

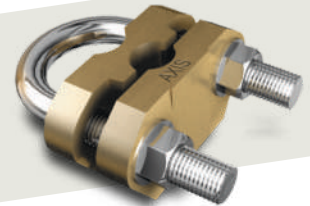

EL

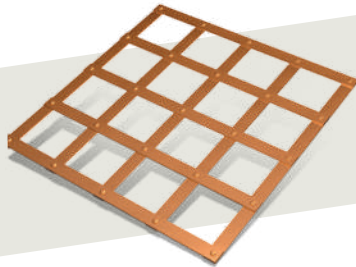

EPSC



EPCB



EPP



WMC



SBB



RWP



TEB



PC



TRANSFORMER FITTING

EB



PEC

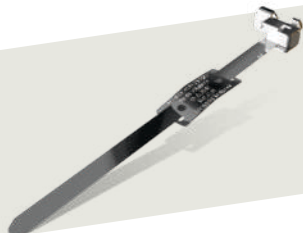

AEL



EP



Flat Tape System

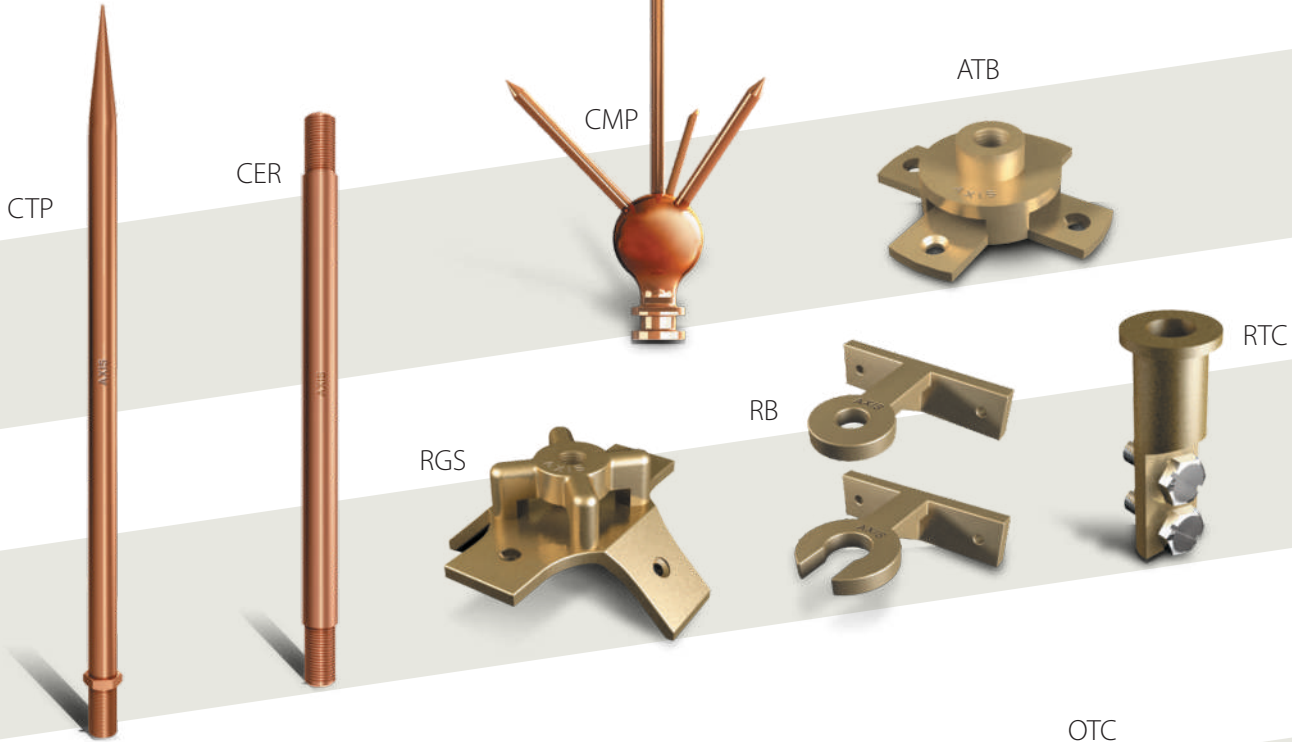

Tape Fixings

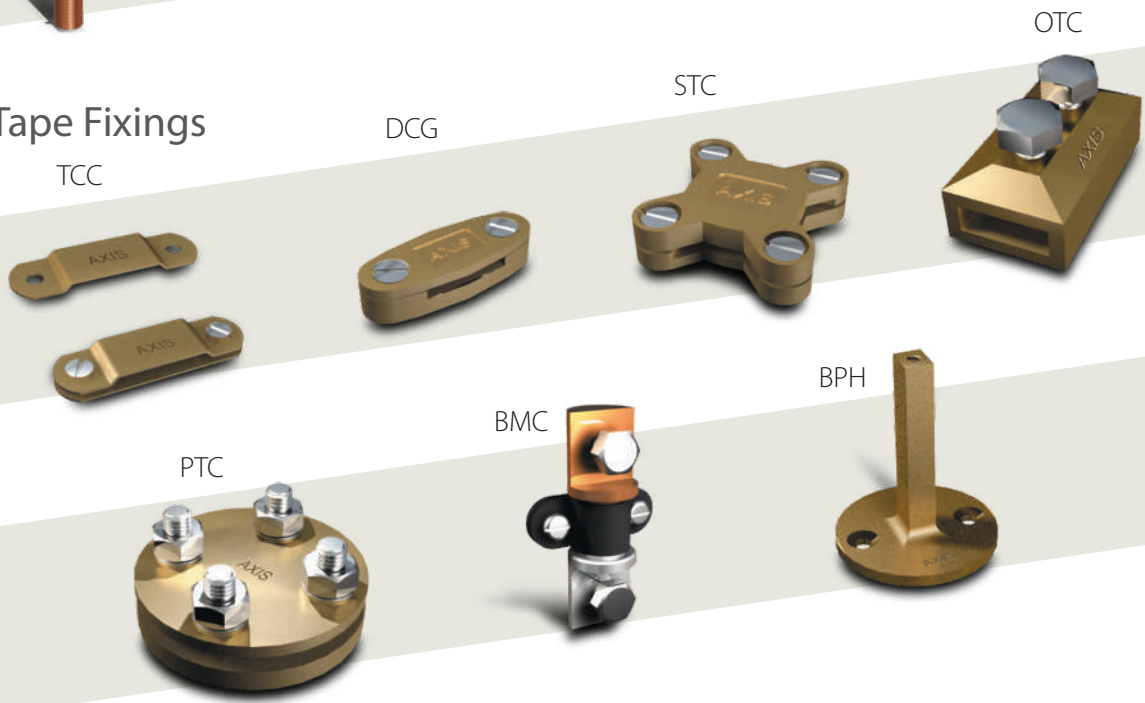

Earth Bar & Disconnecting Link

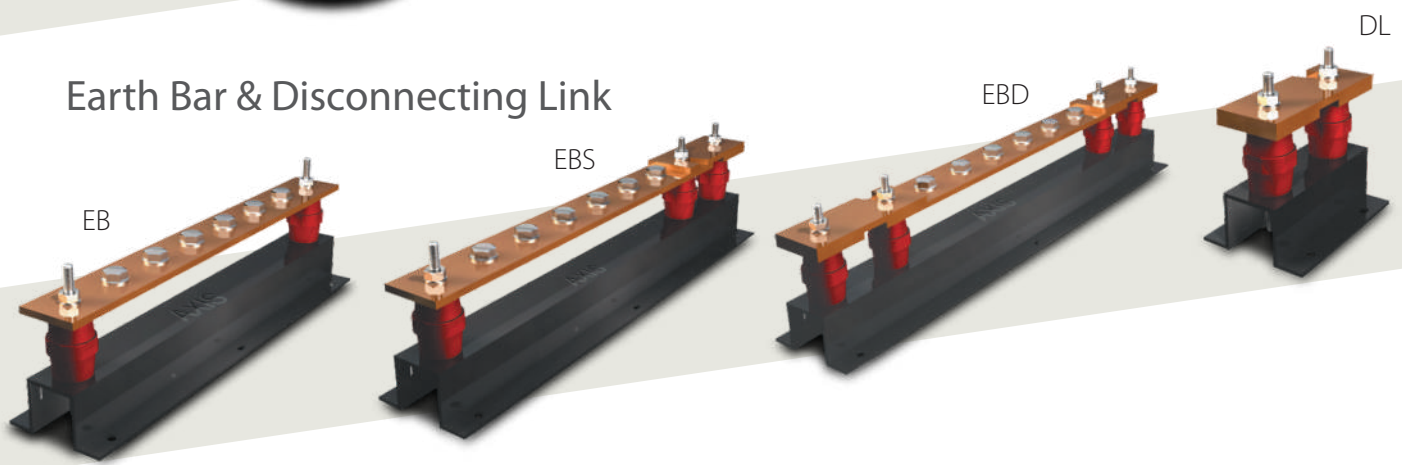

Circular Conductor System

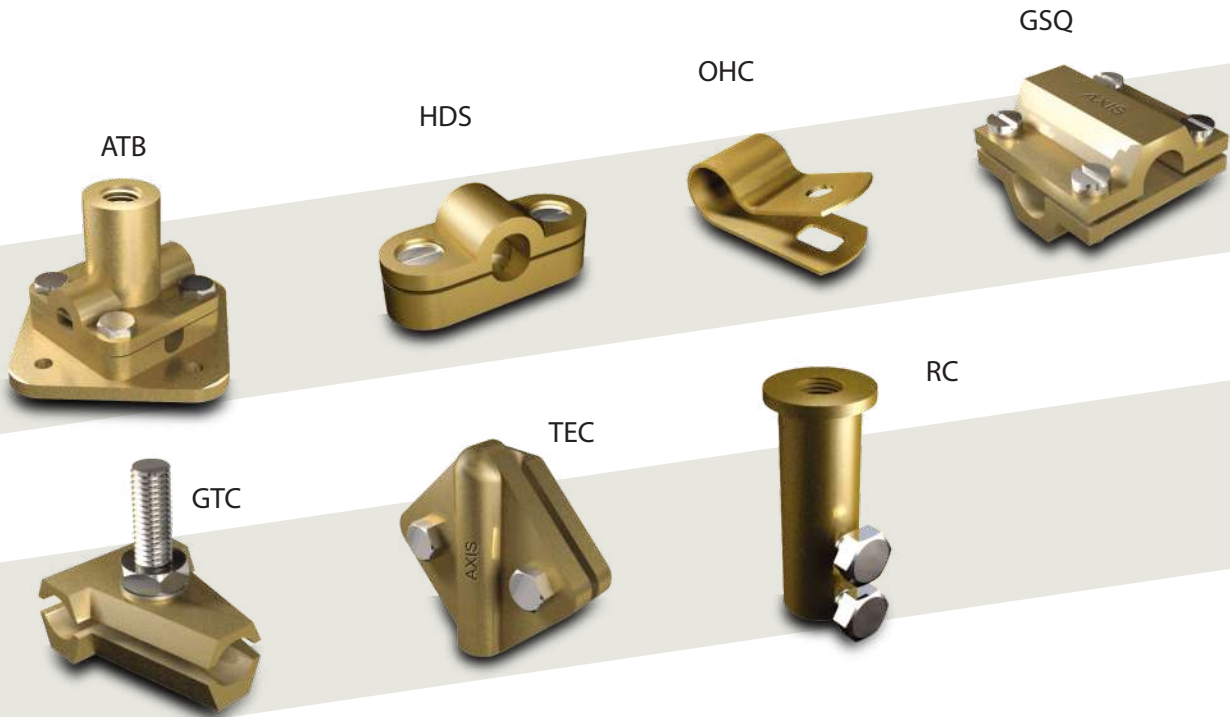

Grounding Conductors

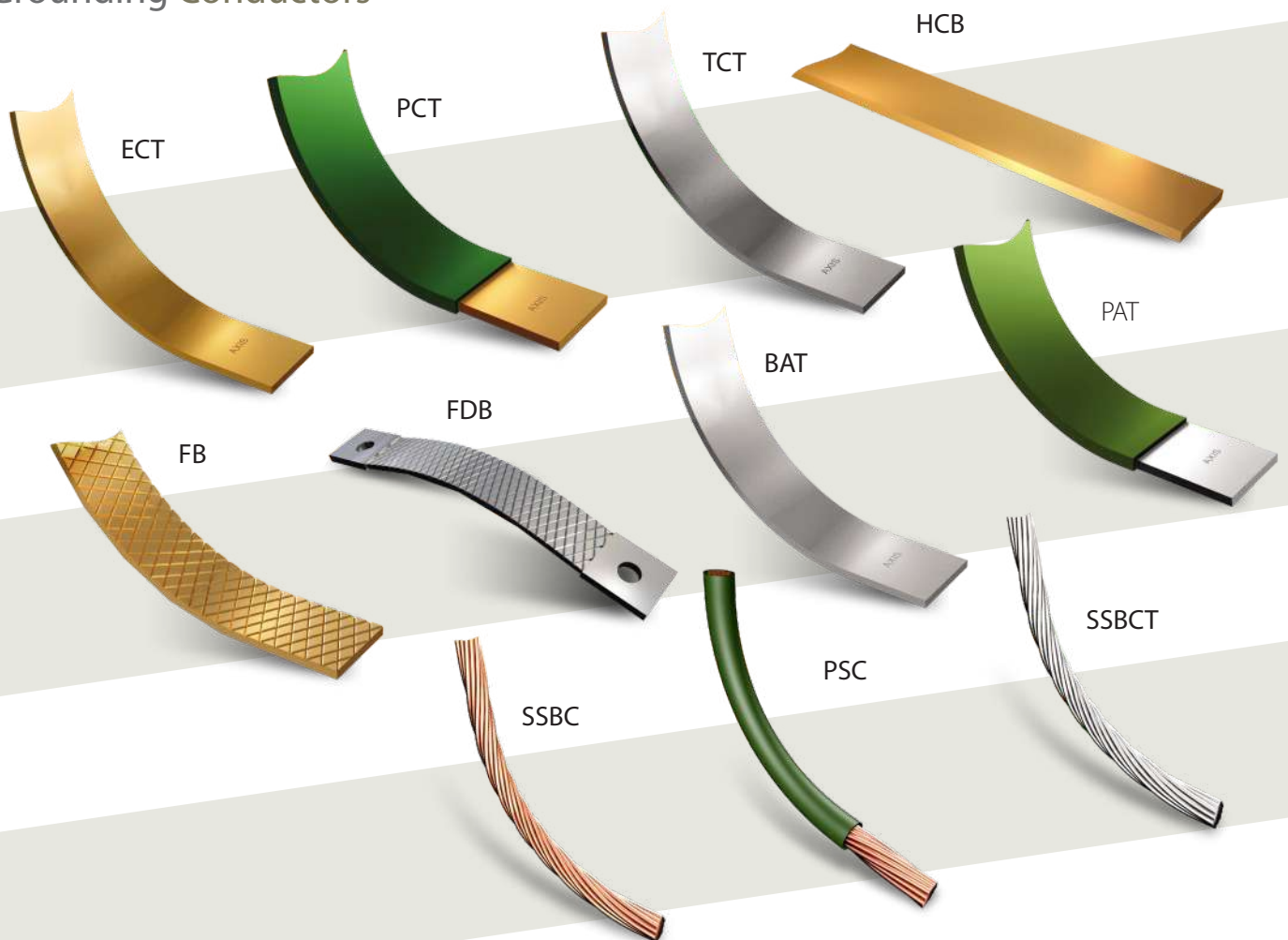

Grounding & Lightning Protection System and Exo Thermic Welding

AXIS provides complete range of E & LP products & system in order to achieve total protection to the Structures, Equipment and community. These products are manufactured in accordance to International standards such as BS EN 50164, UL & IS



Cable Lugs & Connectors

Axis manufactures wide range of Lugs and Connectors sizes ranging from 1.5mm² -1200mm² of Copper, Aluminum & Bimetal. These products are Compression or Bolted type. Popular standards such as BSEN, IS & UL are followed to manufacture and to test these Connectors.



Cable Management System

AXIS Cable Glands and accessories are manufactured according to the functional requirements of IEC 62444 and DIN standards. AXIS Cable Cleats are manufactured in accordance with IEC 61914. AXIS Cable Ties can be supplied with other accessories like Markers, I.D. Tags & Carriers used in oil refineries, petrochemical industries and other utilities worldwide. These cable ties comply to UL-1565 and BS EN 62275 standards.

